

ANSI Symbol

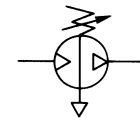

Handle Type

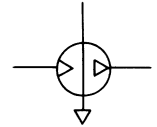

Air Pilot Operated

Increases main line pressure up to two times. Saves energy and money.

The booster regulator, when connected to air supply line, increases pressure up to two times.

Main air supply pressure may be set low.

Use booster regulator only on branches where higher pressure is needed.

Desired pressure increase easily adjusted.

Almost no temperature increase: additional cooling units not needed.

The booster regulator works without any electrical inputs.

## Specifications

Pressure increase ratio	Max 1:2
Media	Air
Proof pressure psig (MPa)	220 (1.5)
Max. working pressure psig (MPa)	150 (1.0)
Set pressure range psig (MPa)	30~150 (0.2~1.0)
Ambient and media temp. range	35° ~ 120° F (2° ~ 50° C)
Lubrication	Non-Lube
Installation	Horizontal
Pressure adjustable mechanism	Relief style

## Model

	Handle Type		Air Pilot Operated Type		
	NVBA2100-T03	NVBA4100-T04	NVBA2200-T03	NVBA4200-T04	
Max. flow SCFM (NI/min.)*	28 (1000)	63 (1900)	28 (1000)	63 (1900)	
Port Size (IN, OUT) NPTF	3/8	1/2	3/8	1/2	
EXH. port size NPTF	3/8	1/2	3/8	1/2	
Pilot port size	—		1/8 NPTF		
Pilot pressure psig (MPa)	—		15 ~ 75 (0.1~0.5)		
Weight lbs. (kgf)	8.4 (3.8)	16.5 (7.5)	8.4 (3.8)	16.4 (7.5)	
Option	Pressure gauge	VBA2-G3	K50A-MP1.0-N02M (2 locations)	VBA2-G3	K40A-MP1.0-N01M (2 locations)
	Silencer	NAN300-N03	NAN400-N04	NAN300-N03	NAN400-N04

\*Pressure: IN = OUT = 75 PSI (5kgf/cm<sup>2</sup>)

## Related Equipment

Type	NVBA2100 • 2200	NVBA4100 • 4200
Mist Separator	NAM450-N04, N06	NAM5500-N06, N10
Exhaust Cleaner	NAMC510-N06	NAMC610-N10

## Repair Kit

Type	NVBA2100	NVBA4100	NVBA2200	NVBA4200
Lower	KT-VBA2100-1-P	KT-VBA4100-P	KT-VBA2200-1	KT-VBA4200-1
Upper/Lower	KT-VBA2100-1	KT-VBA4100-1	—	—

How To Order  
NVBA2100-4200

N
VBA
2
1
00
T
03
GN

**Version**

- N — U.S.A.
- E — Europe\*
- Nil — Japan, Asia, Australia

\*Special order only

**Booster regulator**

**Body size**

- 2 — 3/8
- 4 — 1/2

**Type of pressure adjustment**

- 1 — Handle type
- 2 — Air pilot operated type

**Option**

- G — Pressure gauge
- N — Silencer

**Port size**

Code	Port size	Applicable model
03	3/8	NVBA2100,2200
04	1/2	NVBA4100,4200

**Port thread**

Code	Thread	Applicable
T	NPTF	USA
F*	G (PF)	Europe*
Nil	Rc (PT)	Japan, Asia, Australia

\*Special order

## Operation

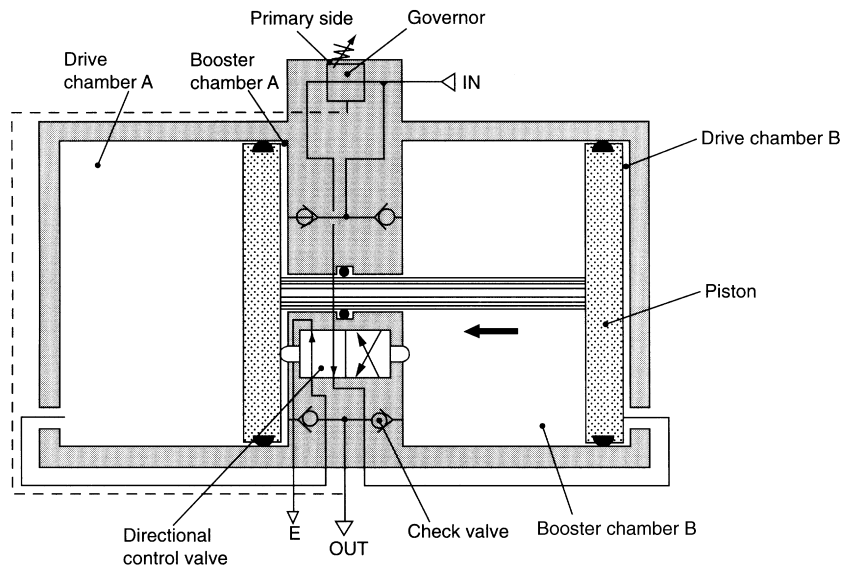

Primary air pressure is supplied from the IN port to the booster chambers A and B via the check valves and drive chamber B via the governor and directional control valve. The pressure in booster chamber A and drive chamber B forces the piston to move, pressurizing the air in booster chamber B, which, subsequently, exits from the OUT port via the check valve. When the piston reaches its stroke end, it switches the directional control valve to vent the pressure in drive chamber B and to supply air pressure to drive chamber A. The process will then repeat, ensuring a continuous supply of air with a pressure higher than that entering the IN port. Secondary pressure is fed back to the governor, allowing accurate control of output pressure.

## Applications

- 1 Equipment that requires higher pressure than that of plant lines.
- 2 Protects downstream equipment from pressure fluctuations.
- 3 Increases the power of an actuator with out changing to a larger cylinder.

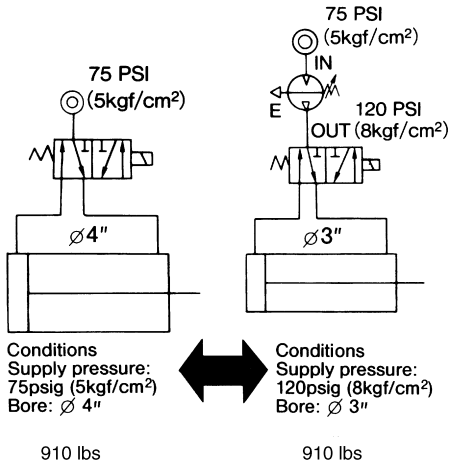

- 4 Increases the effective hydraulic pressure of a Air Hydro Unit.
- 5 A compact drive unit, i.e. small cylinder is required.

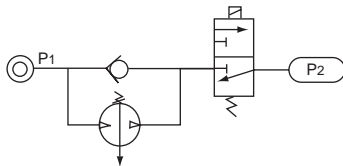
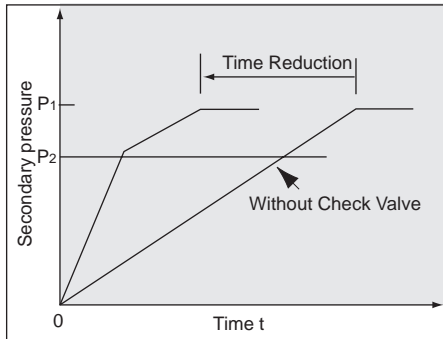

- 6 High pressure air is required without using electric power.

## Flow Characteristics

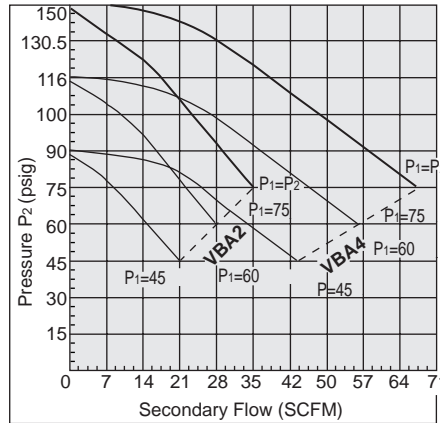

## Pressure Characteristics

Conditions: Supply pressure 100 psig  
Secondary pressure 145 psig  
Flow .7 SCFM

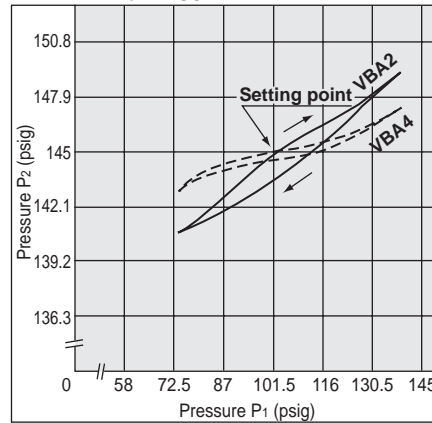

## Pulsation

.35 (10), .71 (20), 1.34 ft³ (38) Tank

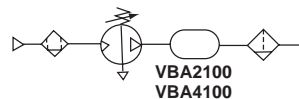
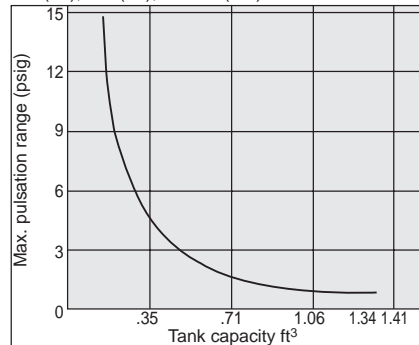

## Charge Characteristics

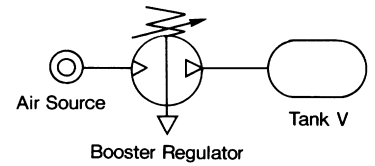

### Example For NVBA4

The required time to increase tank pressure from 120 PSI to 150 PSI at 75 PSI supply pressure is calculated as follows.

$$\frac{P_2}{P_1} = \frac{120}{75} = 1.6$$

$$\frac{P}{P_1} = \frac{150}{75} = 2.0$$

With the pressure increase ratio from 1.6 to 2.0, the time of 2.4 sec. (t) is given for .35ft³ tank by the graph.

(3.5-1.1=2.4)

Then, the charging time (T) for a 10 ft³ tank,

$$T = t \times \frac{V}{.35}$$

$$= 2.4 \times \frac{10}{.35}$$

$$= 69(\text{sec.})$$

## Charge Characteristics

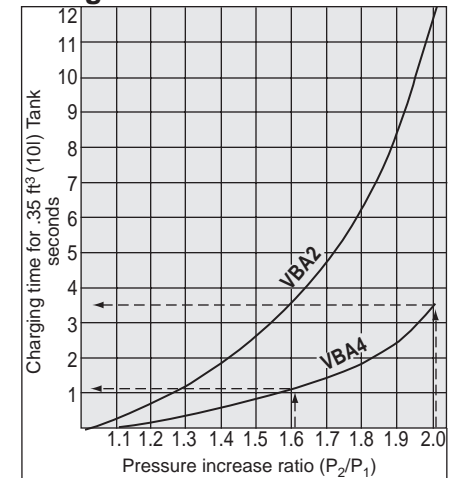

Booster Regulator  
NVBA2100~4200

## Precautions

### Air Quality

Poor quality air will increase the sliding resistance of moving parts, resulting in failure of the booster regulator to meet its specified characteristics.

Install an air filter of  $5\mu\text{m}$  (NAF3000,4000) filtration rate or its equivalent at the primary pressure side.

Piping should be carefully flushed to remove dust and scale completely.

### Connection Diagram

Lubricators should be connected to the secondary side of the booster regulator.

Install a mist separator (example: NAFM 3000, 4000) if the supply air contains oil mist and/or carbon.

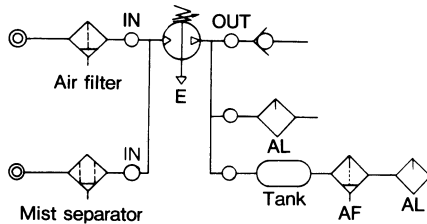

### Exhaust

Install either a silencer (NAN300-N03 or NAN400-N04) or an exhaust cleaner (NAMC610-N10) at the exhaust port of the booster regulator.

### Installation

The booster regulator should be installed with its piston in a horizontal position.

Securely tighten the mounting bolts to prevent dislocation of the booster regulator. Where transmission of vibration should be avoided, use vibration-isolating rubber pads.

### Residual Pressure

To enable exhaust of residual pressure in case of an emergency, install a 3 port valve at the OUT port of the booster regulator.

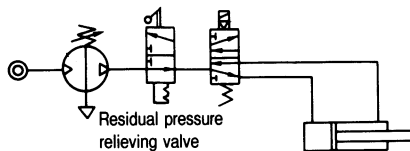

### Pressure Setting

#### Handle Type

Pull up the adjustment handle and turn it as indicated by the arrow to adjust the pressure. Push the handle to lock it in place.

If the secondary pressure setting is reduced, pressure is relieved through the governor.

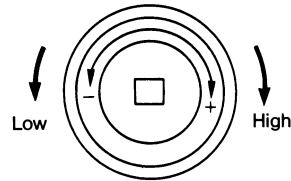

#### Air Pilot Operated Type

Secondary pressure is twice the pilot pressure.

A shift of pilot pressure from 30 PSI (0.2 MPa) to 60 PSI (0.4 MPa) results in a change of secondary pressure from 60 PSI (0.4 MPa) to 120 PSI (.83 MPa).

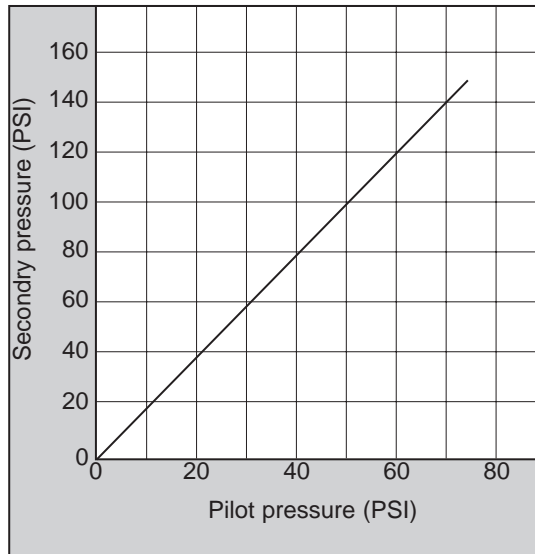

For on-site control, connect a small air regulator to the pilot port (P) of the booster regulator.

SMC regulators, model NAR2000 or NAW2000 are recommended for regulation of the pilot pressure.

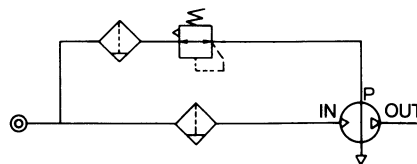

Handle Type

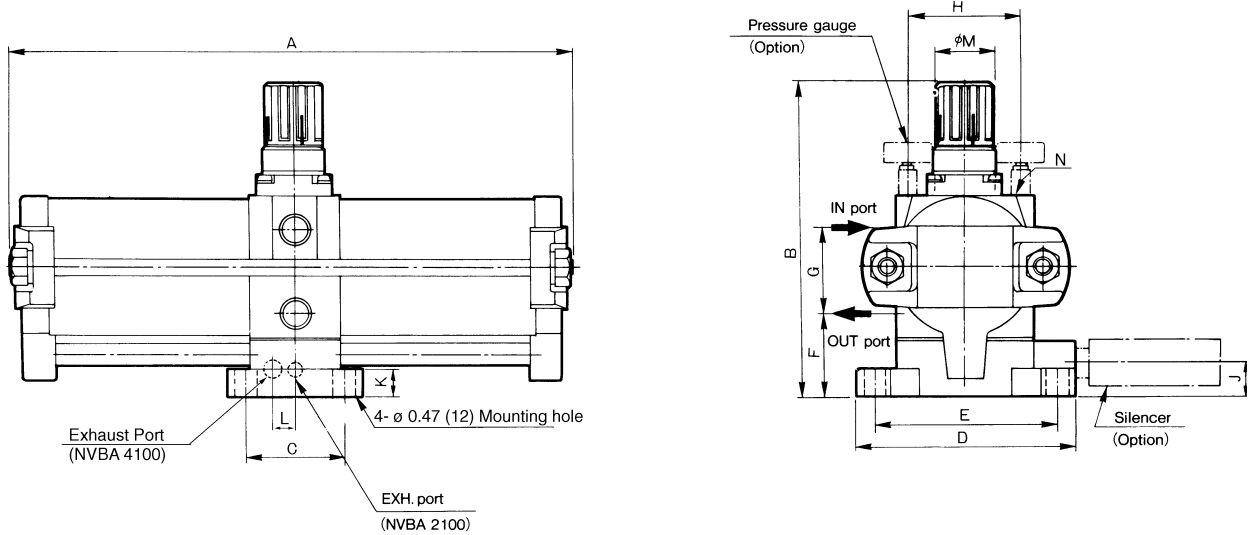

Millimeters in Parentheses

Model	Port Size NPTF	A	B	C	D	E	F	G	H	J	K	L	φM	N
NVBA2100-T03	3/8	11.81 (300)	6.69 (170)	2.09 (53)	4.65 (118)	3.86 (98)	1.81 (46)	1.69 (43)	2.38 (60.5)	0.71 (18)	0.59 (15)	—	1.22 (31)	1/16 NPTF
NVBA4100-T04	1/2	15.91 (404)	8.17 (207.5)	3.78 (96)	5.91 (150)	5.12 (130)	2.47 (62.8)	2.44 (62)	3.54 (90)	0.67 (17)	0.59 (15)	0.79 (20)	1.57 (40)	1/8 NPTF

Air Pilot Operated Type

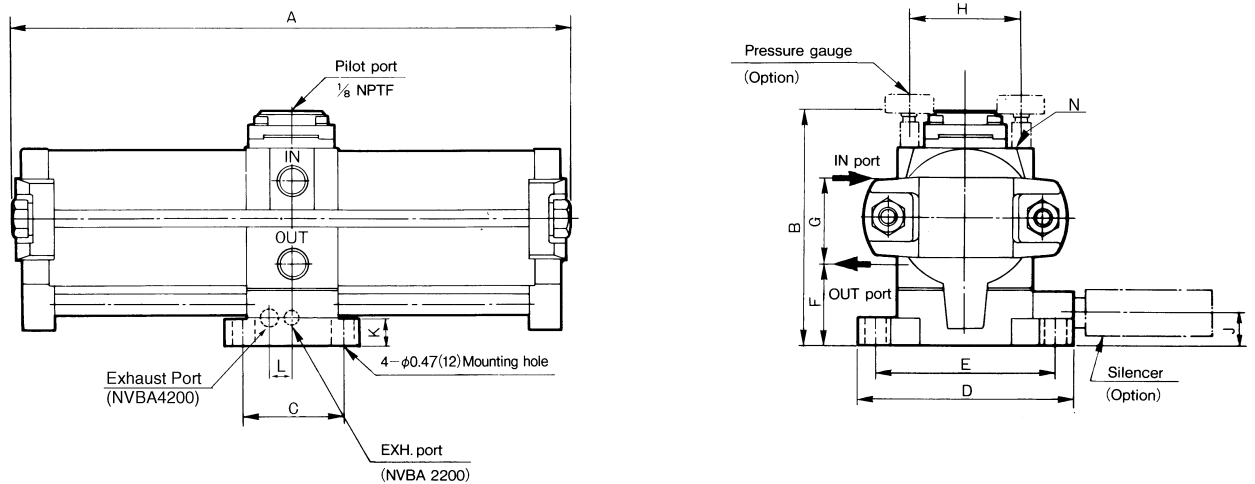

Millimeters in Parentheses

Model	Port Size NPTF	A	B	C	D	E	F	G	H	J	K	L	N
NVBA2200-T03	3/8	11.81 (300)	4.98 (126.5)	2.09 (53)	4.65 (118)	3.86 (98)	1.81 (46)	1.69 (43)	2.38 (60.5)	0.71 (18)	0.59 (15)	—	1/16 NPTF
NVBA4200-T04	1/2	15.91 (404)	6.57 (167)	3.78 (96)	5.91 (150)	5.12 (130)	2.47 (62.8)	2.44 (62)	3.54 (90)	0.67 (17)	0.59 (15)	.79 (20)	1/8 NPTF



## Specifications

Booster Valve	NVBA1110	NVBA1111
Pressure increase ratio	Max. 1:2	Max. 1:4
Fluid	Air	
Proof pressure psig (MPa)	435 (3.0)	
Input supply pressure psig (MPa)	15 ~ 150 (0.1 ~ 1.0)	
Set pressure range psig (MPa)	30 ~ 290 (0.2 ~ 2.0)	
Ambient and fluid temperature	35 ~ 120° F (2 ~ 50° C)	
Lubrication	Non-Lube	
Installation	Horizontal	
Pressure adjustable mechanism	Relief style	
* Max. Flow	14.2SCFM (400N/min)	17.8SCFM (500N/min)
IN, OUT, EXH Port Size	1/4 NPTF	
Weight lbs (kgf)	1.87 (0.85)	2.16 (0.98)

\*Pressure: IN = OUT = 150 PSI (1.0 MPa)

## Related Equipment

Mist Separator	NAM250-N02
Exhaust Cleaner	NAMC310-N03

## Repair Kit

Lower	KT-VBA1110-P	KT-VBA1111-P
Upper/Lower	KT-VBA1110-1	KT-VBA1111

## Options

Gauge	G27-20-R1
Silencer	NAN200-N02

## How to Order

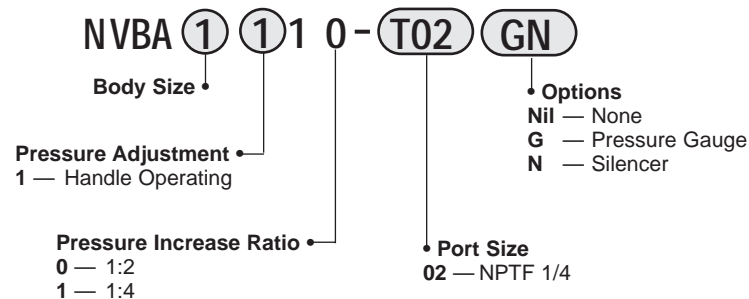

## Applications

- ① Equipment requiring higher pressure than that of plant lines.
- ② Protects downstream equipment from pressure fluctuations.
- ③ Increases the power of an actuator.

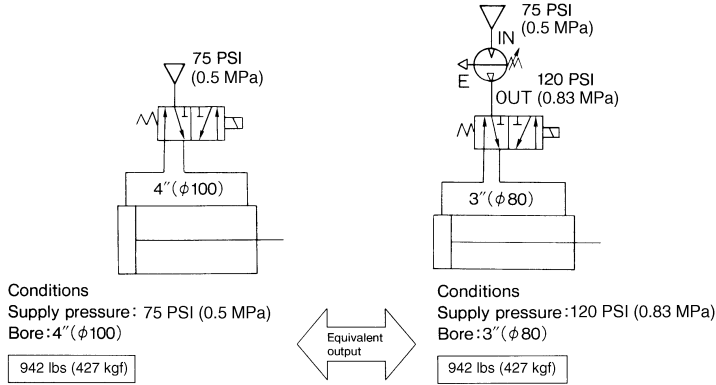

- ④ Increases the effective hydraulic pressure of a Air Hydro Unit.
- ⑤ A compact drive unit, i.e. small cylinder is required.

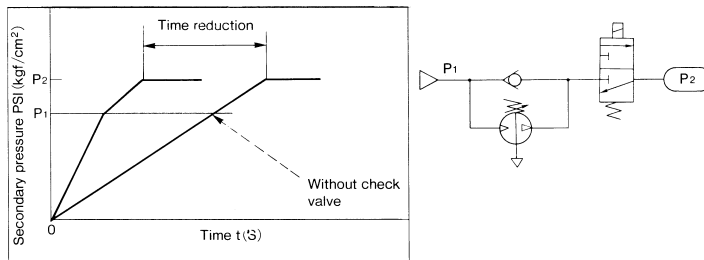

- ⑥ High pressure air is required without using electric power.

Booster Regulator  
NVBA1100/1111

## NVBA1110

### Flow Characteristics

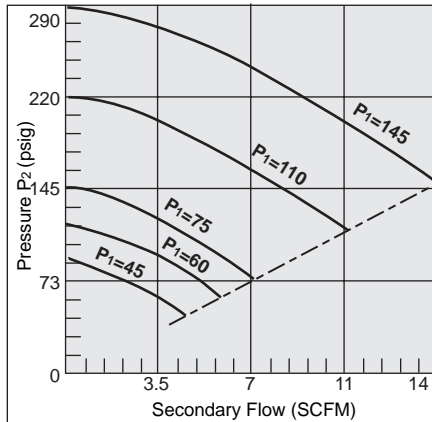

### Pressure Characteristics

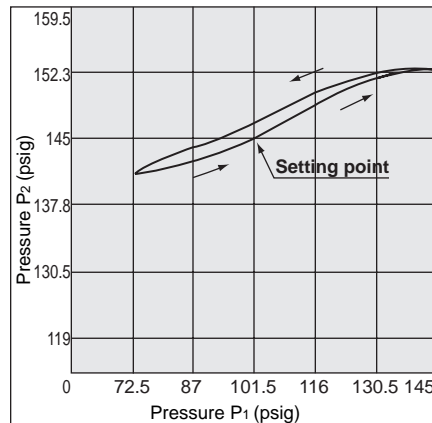

Conditions: Supply pressure 87psig  
Secondary pressure 145psig  
Flow .4 SCFM

### Charge Characteristics

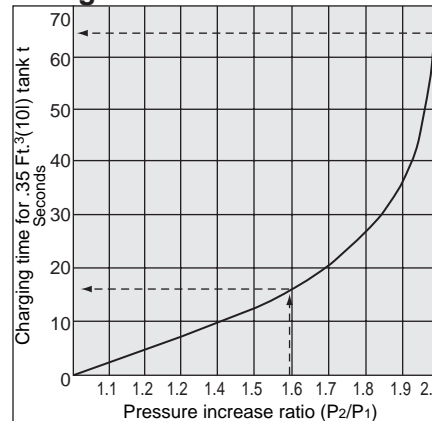

## NVBA1111

### Flow Characteristics

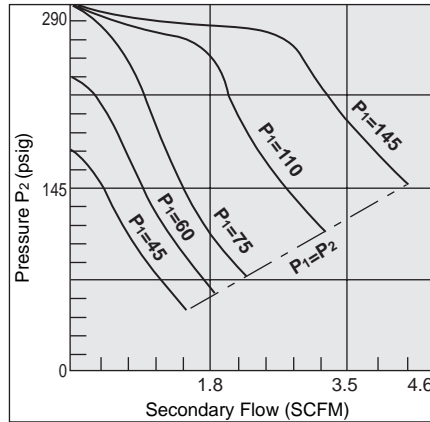

### Pressure Characteristics

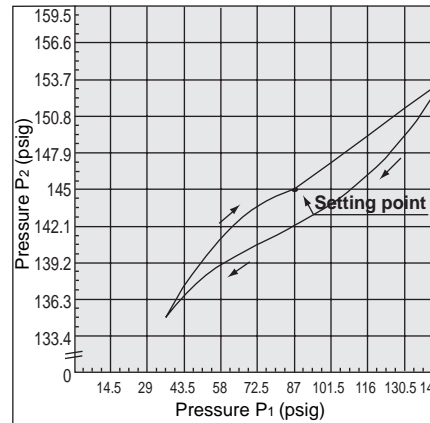

Conditions: Supply pressure 87psig  
Secondary pressure 145psig  
Flow .4 SCFM

### Charge Characteristics

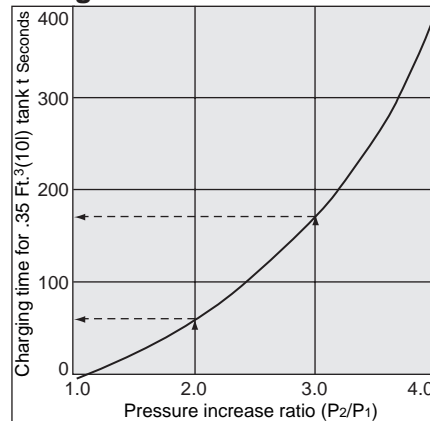

### Example for NVBA1110

The required time to increase tank pressure from 120 psi to 150 psi at 75 psi supply pressure is calculated as follows:

$$\frac{P_2}{P_1} = \frac{120}{75} = 1.6$$

$$\frac{P_2}{P_1} = \frac{150}{75} = 2.0$$

With the pressure increase ratio from 1.6 to 2.0, the time of 49 seconds (t) is given for .35 ft<sup>3</sup> tank by the graph (65-16=49). Then, the charging time (T) for a .5 ft<sup>3</sup> tank,

$$T = t \times \frac{V}{.35}$$

$$= 49 \times \frac{.5}{.35}$$

$$= 70 \text{ seconds}$$

### Example for NVBA1111

The required time to increase tank pressure from 150 psi to 225 psi at 75 psi supply pressure is calculated as follows:

$$\frac{P_2}{P_1} = \frac{150}{75} = 2.0$$

$$\frac{P_2}{P_1} = \frac{225}{75} = 3.0$$

With the pressure increase ratio from 2.0 to 3.0, the time of 110 seconds (t) is given for .35 ft<sup>3</sup> tank by the graph (170-60=110). Then, the charging time (T) for a .5 ft<sup>3</sup> tank,

$$T = t \times \frac{V}{.35}$$

$$= 110 \times \frac{.5}{.35}$$

$$= 157 \text{ seconds}$$



Dimensions Inch (mm)

